

Volere 22

**Owners Manual • Bedienungsanleitung
Manuel de l'utilisateur • Manuale dell'utente**

PRB3050B/ PRB3050BI

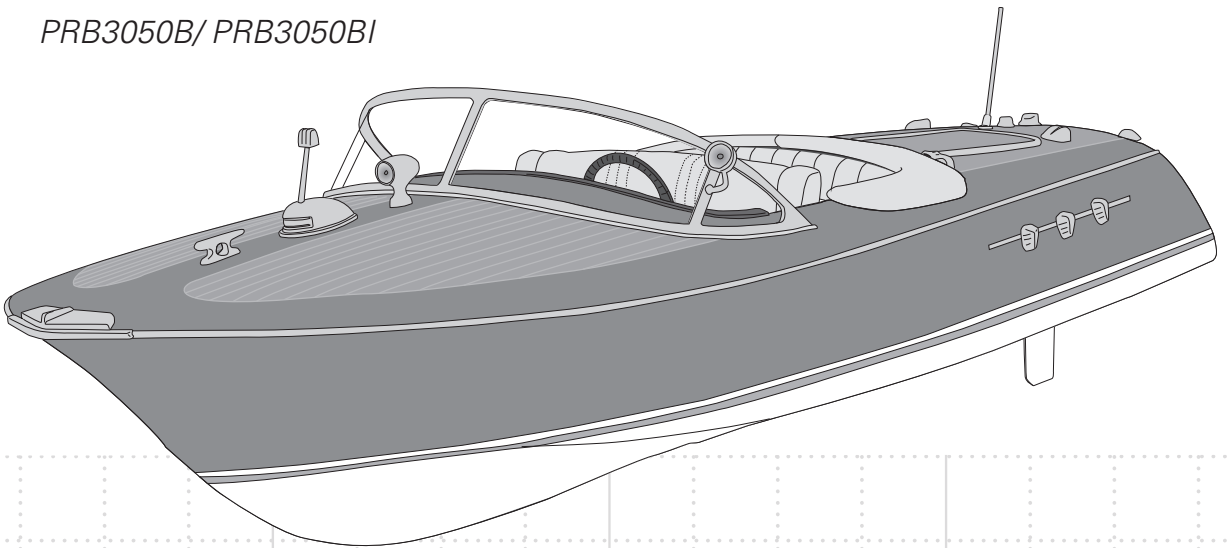

NOTICE

All instructions, warranties and other collateral documents are subject to change at the sole discretion of Horizon Hobby, Inc. For up-to-date product literature, visit www.horizonhobby.com and click on the support tab for this product.

MEANING OF SPECIAL LANGUAGE

The following terms are used throughout the product literature to indicate various levels of potential harm when operating this product:

NOTICE: Procedures, which if not properly followed, create a possibility of physical property damage AND little or no possibility of injury.

CAUTION: Procedures, which if not properly followed, create the probability of physical property damage AND a possibility of serious injury.

WARNING: Procedures, which if not properly followed, create the probability of property damage, collateral damage, and serious injury OR create a high probability of superficial injury.



WARNING: Read the ENTIRE instruction manual to become familiar with the features of the product before operating. Failure to operate the product correctly can result in damage to the product, personal property and cause serious injury.

This is a sophisticated hobby product and NOT a toy. It must be operated with caution and common sense and requires some basic mechanical ability. Failure to operate this Product in a safe and responsible manner could result in injury or damage to the product or other property. This product is not intended for use by children without direct adult supervision. Do not attempt disassembly, use with incompatible components or augment product in any way without the approval of Horizon Hobby, Inc. This manual contains instructions for safety, operation and maintenance. It is essential to read and follow all the instructions and warnings in the manual, prior to assembly, setup or use, in order to operate correctly and avoid damage or serious injury.

Safety Precautions and Warnings

As the user of this product, you are solely responsible for operating in a manner that does not endanger yourself and others or result in damage to the product or the property of others.

- When handling and/or transporting your boat, always pick up the boat from the front, keeping all moving parts pointed away from you.
- Always keep a safe distance in all directions around your model to avoid collisions or injury. This model is controlled by a radio signal subject to interference from many sources outside your control. Interference can cause momentary loss of control.
- Always operate your model in open spaces away from full-size vehicles, traffic and people.
- Always carefully follow the directions and warnings for this and any optional support equipment (chargers, rechargeable battery packs, etc.).
- Always keep all chemicals, small parts and anything electrical out of the reach of children.
- Always avoid water exposure to all equipment not specifically designed and protected for this purpose. Moisture causes damage to unprotected electronics.
- Never place any portion of the model in your mouth as it could cause serious injury or even death.
- Never operate your model with low transmitter batteries.

Age Recommendation:

Not for children under 14 years. This is not a toy.

Table of Contents

Introduction.....	3	Rudder Centering.....	8
Recommended Tools and Materials.....	3	Boating Tips.....	8
Product Inspection.....	3	Motor Care.....	8
Contents.....	3	When You are Finished.....	9
Specifications.....	3	Maintenance and Repair.....	9
Boat Stand Assembling.....	3	Lubrication.....	9
Charging Warnings.....	4	Driveshaft Maintenance.....	10
Battery Charger.....	4	Checklists.....	11
Initial Charge.....	4	Before Boating.....	11
Antenna Tube Installation.....	5	After Boating.....	11
Decal Application.....	5	Troubleshooting Guide.....	11
Scale Features.....	5	Limited Warranty.....	13
Boat Battery Installation.....	5	Parts Contact Information.....	14
Transmitter Battery Installation.....	5	Contact Information.....	14
Transmitter Controls.....	6	FCC Information.....	15
Radio System Check.....	6	Compliance Information for the European Union.....	15
Getting Started.....	7	Identification of Components.....	56
Binding.....	7	Replacement Parts.....	57
Testing your Boat in the Water.....	8	Optional Parts.....	57

Introduction

Pro Boat® RC models look as good as they perform. Our boats, which include everything from scale sailboats to fully licensed powerboats, exceed expectations and provide years of radio control fun and excitement. Whether your passion leads you towards the pure serenity of sailing or the all-out speed of a Deep-V, Pro Boat models fit your taste, budget and lifestyle. You can count on us to be available any time you need help—the brand is backed by Horizon Hobby, one of the world's largest distributors of hobby-grade RC products. The Pro Boat brand will help you turn your boating passion into a reality, whether you're new to the hobby or an old pro.

Please read this manual for operation and maintenance instructions.

Register your boat online at www.proboatmodels.com.

Recommended Tools and Materials

- Paper towel
- Rubbing alcohol
- Medium threadlock
- Household light machine oil
- Motor spray (DYN5500)
- 2.5mm ball type hex wrench
- Small Flat Blade Screwdriver
- Fine sandpaper or Emery cloth
- Clear tape (PRB0102)
- Pro Boat® Marine Grease and Gun (PRB0100)
- Medium CA (cyanoacrylate adhesive) or epoxy adhesive

Product Inspection

Carefully remove the boat and radio transmitter from the box. Inspect the boat for damage. If you find damage is present, please contact the hobby shop where you purchased your boat.

Contents

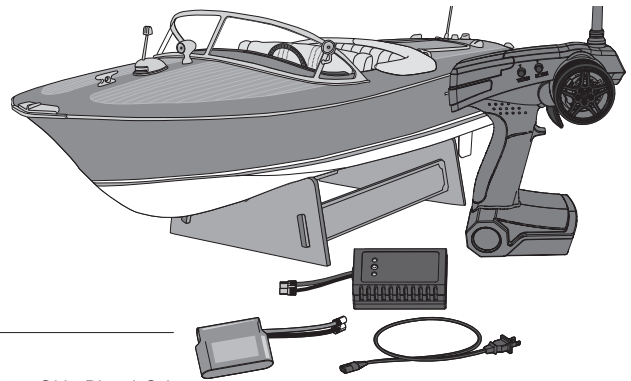

Specifications

Length	22.0 in (559mm)
Beam (width)	7.5 in (191mm)
Hull height	5.0 in (127mm)

Transmitter	2.4GHz Pistol Grip
Receiver	2-channel 2.4GHz
Hull Material	ABS Plastic
Motor	550 Brushed Motor, water-cooled
ESC	Electronic speed control (ESC) with reverse

Battery and Charger

Dynamite® 7.2V 1200mAh Ni-MH battery (DYN1472)
 Dynamite 2A Peak Charger (DYN4113)
 4 AA batteries (sold separately) are required to operate the transmitter

Boat Stand Assembling

1. Insert the tabs of the side stand pieces in the slots in the end pieces. The lettering on the side pieces should face out from the sides of the stand.
2. While the stand is level on a flat surface, apply medium CA or epoxy adhesive to secure the side stand pieces to the ends.
3. Allow the adhesive to dry before placing your boat on the stand.

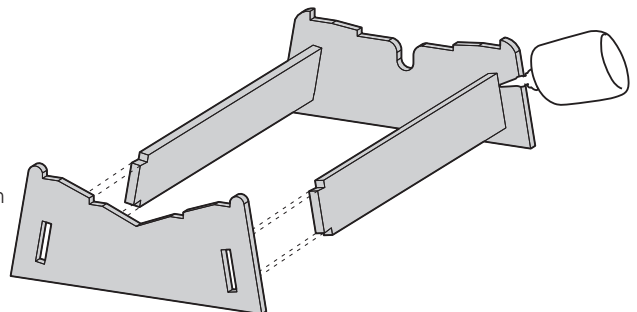

Charging Warnings



WARNING: Failure to exercise caution while using this product and comply with the following warnings could result in product malfunction, electrical issues, excessive heat, FIRE, and ultimately injury and property damage.

- Read all safety precautions and literature prior to use of this product.
- Never leave the battery and charger unattended during use.
- Never allow children under 14 years of age to charge battery packs.
- Never attempt to charge damaged batteries.
- Never charge a battery if the cable has been pinched or shorted.
- Never allow the batteries or charger to come into contact with moisture at any time.
- Never charge batteries in extremely hot or cold places (recommended between 50–80°F (10–26°C)) or in direct sunlight.
- Always use only Ni-MH rechargeable batteries. This charger cannot charge batteries such as “heavy duty”, “alkaline battery”, “mercury battery” or “lithium battery”.
- Always connect to the charger correctly.
- Always disconnect the battery and charger after charging and let them cool between charges.
- Always inspect the battery before charging.
- Always terminate all processes and contact Horizon Hobby if the product malfunctions.
- Always make sure you know the specifications of the battery to be charged or discharged to ensure it meets the requirements of this charger.
- Always connect the charge cable to the charger first, then connect the battery to avoid short circuit between the charge leads. Reverse the sequence when disconnecting.
- Always constantly monitor the temperature of the battery pack while charging.
- Always end the charging process if the charger or battery becomes hot to the touch or starts to change form during the charge process.

Battery Charger

This light and compact charger (DYN4113) quickly and easily charges 5–8 cell Ni-MH battery packs with an installed EC3™ power connector.

Instructions

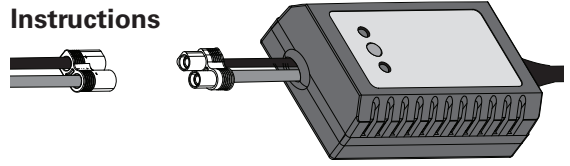

1. Connect the AC power cord to the power slot on the charger, then connect the other end of the power cord to an AC power source.
2. The Power LED and Charging LED will turn GREEN when the charger is connected to the AC power source.
3. Connect the battery pack connector to the charge connector.
4. Press the On/Off button to charge the battery. The Charging LED turns RED.
5. When the battery pack is fully charged, the Charging LED will turn GREEN.
6. Press the On/Off button to stop charging. Disconnect the battery pack connector from the charge connector.



CAUTION: If at any time during the charge process the battery pack becomes hot to the touch, unplug the battery immediately and discontinue the charge process.

Initial Charge

Your Dynamite peak voltage detection charger includes safety circuitry and programming allowing the charger to stop charging after 15 minutes, if it senses any issues that have come up in charging. The high electrical resistance commonly found in new, unconditioned, Ni-MH batteries can cause this safety circuit to activate turning the charger off before a full charging cycle is complete. This is commonly known as a “false peak” in your battery charge. Should this occur during your first charge cycle, it does not necessarily indicate a failure of either your charger or battery. Instead it shows that the charger is functioning properly and that the battery is not yet fully conditioned. To complete your first full charging cycle in the event of a false peak, restart the charger by pressing the Start button again. Repeat this process until the charge cycle continues to charge past 15 minutes. It may take as many as 2 to 4 restarts to complete your first one or two full charge cycles. Once your charger completes a charge cycle longer than 15 minutes your battery will be fully charged. A typical first full-charge cycle should run for 45 to 90 minutes, depending on the self-discharge condition of the battery since it was shipped from the factory. Once your battery is properly conditioned through a few full charge and discharge cycles, you will see normal operation of the charger by a single press of the start button, followed by a 60 to 90 minute charge cycle.

Antenna Tube Installation

1. Install the short tube (A) over the grommet (B) on the hull (C).
2. Feed the antenna wire (D) of the receiver through the grommet and into the antenna tube (E).
3. Install the antenna tube in the grommet and the cap (F) on the tube.

The antenna must be installed correctly above the boat's water line to get the best reception of your transmitter's signal.

Tip: Secure the antenna wire inside the hull and the tube in the grommet using tape to prevent loss in windy conditions.

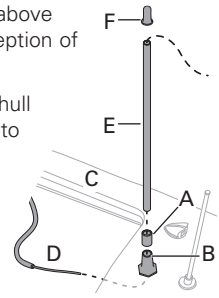

Decal Application

Included decals are intended for display purposes only. Ensure the boat hull is clean. Lift a decal from a sheet and carefully apply it to the boat as you desire. National flag decals may be folded in half around the flag post on the rear of the boat. A triangular flag may be folded in half around the short flag post in front of the windshield.

Scale Features

For display purposes, the steering wheel or other scale features may be installed on the boat.

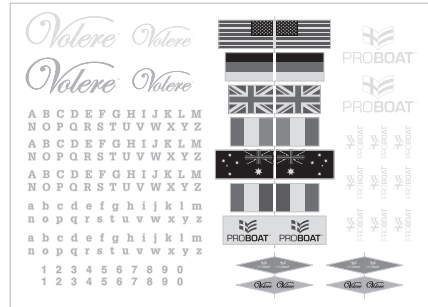

Boat Battery Installation

1. Apply the included hook and loop tape to the battery. Do not cover the battery warning label.

Tip: Clean the battery pack with motor spray or rubbing alcohol and a clean cloth before installing hook and loop tape so adhesive can stick better.

2. Remove the front seat hatch and the rear deck hatch from the boat.
3. In the rear hatch opening, install the battery connector in the boat hull with the connector facing the front of the boat.

4. Install the battery in the left side of the hull with the 2 horizontally-mounted battery cells facing the outside of the hull.

5. Center the battery over the hook and loop tape in the hull, then push the battery down a small amount to secure it.

6. Refer to Getting Started instructions to power on your boat. Install the hatches on the boat before operation in water.

Tip: If desired, apply waterproof tape over the hatch edge to help keep water out of the hull.

IMPORTANT: Always remove the battery from the boat for transport and storage.

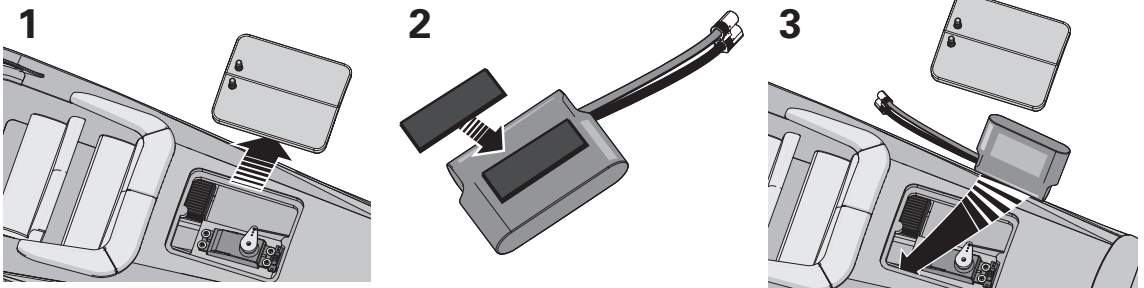

Transmitter Battery Installation

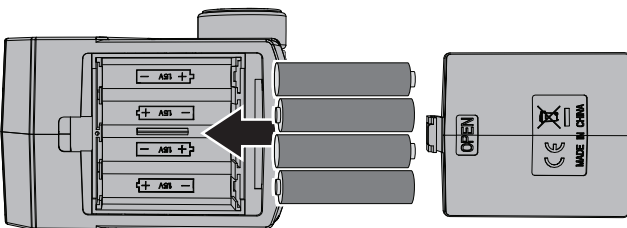

This transmitter requires 4 AA batteries.

1. Remove the battery cover from the transmitter.
2. Install the batteries as shown.
3. Install the battery cover.

Transmitter Controls

Battery Level Indicator

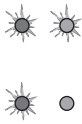

Solid Red and Green: Battery voltage is good (above 4V).

Solid Red: Battery voltage is critically low (below 4V). Replace transmitter batteries.

Reverse Switch

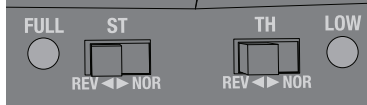

Allows you to change the direction of steering (ST. REV) and throttle (TH. REV) controls. Perform the radio system test to ensure proper function.

Throttle Dual Rate



Adjusts the maximum amount of throttle the vehicle can be given

Power Switch

Power on or off the transmitter

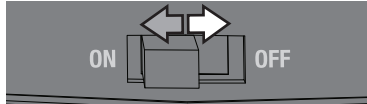

Steering Rate



Adjusts the maximum amount that the rudder moves when the steering wheel is turned left or right

Steering Wheel



Control steering. Right and Left steering (See ST. REV switch)

Throttle Trim



Adjusts the neutral point of the electronic speed control

Throttle Trigger

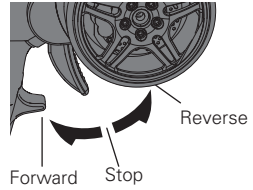

Controls power to the motor for forward or reverse (See TH. REV switch)

Steering Trim



Adjust to make the vehicle drive straight with no input at the steering wheel

Radio System Check

CAUTION: Always keep all body parts, hair and dangling or loose items away from a spinning propeller, as these could become entangled.

NOTICE: Always power on the transmitter before powering on the ESC. Always power off the ESC before powering off the transmitter. Never transport the boat with the battery connected to the ESC.

1. Power on the transmitter.
2. Connect a fully charged battery to the ESC.
3. Power on the ESC and it will beep 3 times.
4. Ensure the rudder moves in the proper direction when the steering wheel is moved left or right.
5. Pull the throttle to full, then return the throttle to neutral, ensuring the propeller turns counterclockwise.

The auto-sensing voltage cutoff will also engage when the ESC detects low battery voltage. Release the throttle and recharge the battery.

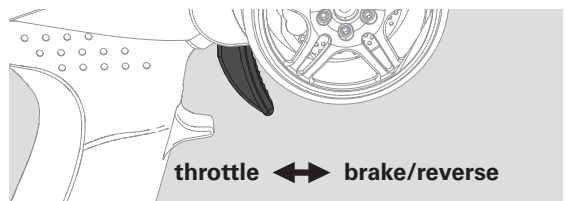
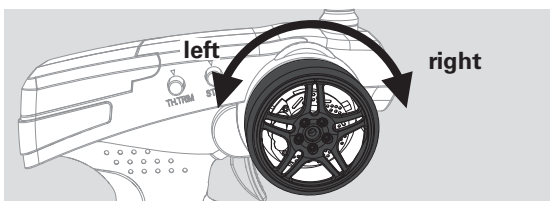

Getting Started

1. Power on the transmitter.
2. Connect the battery.
3. Power on the ESC switch mounted by the steering servo under the rear deck hatch.
4. Test the transmitter's control of the boat (out of water) as shown.
5. Launch the boat into the water and start driving. If the boat does not go straight, adjust the steering trim dial on the transmitter.

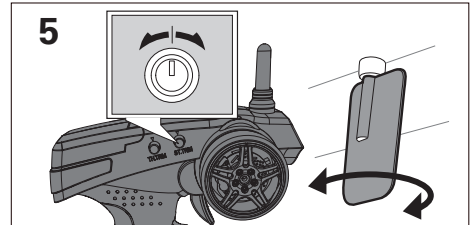
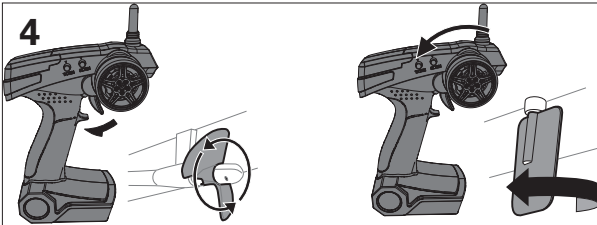
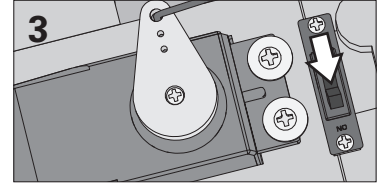
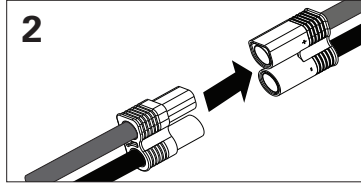
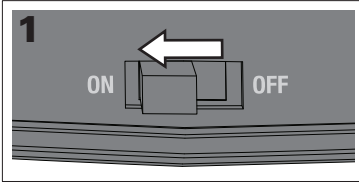

Binding

The included receiver and transmitter are bound at the factory. It is not likely that you will need to re-bind the receiver. However, you must re-bind when you desire to operate this receiver using another Pro Boat 2.4GHz transmitter or setting the failsafe.

Binding is the process of programming the receiver to recognize the GUID (Globally Unique Identifier) code of a single specific transmitter. The included transmitter and receiver are bound at the factory. If you need to rebind, follow the instructions below.

1. Power off the transmitter and ESC (electronic speed control).
2. Connect a fully charged battery pack to the ESC.
3. Power on the ESC. The RED LED on the ESC flashes.

4. Press the bind button of the receiver. The RED LED on the ESC flashes rapidly.
5. Power on the transmitter.
6. The RED LED on the ESC turns solid when the radio system is bound.

NOTICE: Do not attempt to bind the transmitter and receiver if there are other compatible transmitters in bind mode within 400 feet. Doing so may result in unexpected binding.

Failsafe

In the unlikely event that the radio link is lost during use, the receiver will drive the servos to their preprogrammed failsafe positions (normally no throttle and straight steering). If the receiver is powered on before powering on the transmitter, the receiver will enter failsafe mode, driving the servos to their preset failsafe positions. When the transmitter is powered on, normal control is resumed. Failsafe servo positions are set during binding.

Testing your Boat in the Water

1. Carefully place the boat in the water. If the boat tips forward, or back, or to one side, move the battery in the hull for correct balance.
2. Operate the boat at slow speeds near the shoreline. Avoid objects in the water at all times.
3. When the boat is moving forward, ensure water flows out of the coolant outlet on the boat. If water does not flow out of this outlet, repair any breaks or remove any debris or the motor may overheat.
4. Once you are comfortable operating the boat at slow speeds, it is safe to operate the boat farther from the shore. Always keep your boat in sight while it is in the water.

IMPORTANT: If the boat does not drive straight, adjust the steering trim on the transmitter opposite the direction of drift.

5. Bring the boat back to shore when you notice the boat starting to lose speed.
6. Power off the ESC and disconnect the battery pack.
7. Allow the motor, ESC and battery pack to cool before charging the battery or operating the boat again.

NOTICE: Do not turn off the transmitter first or the receiver may pick up stray signals and run out of control.

Rudder Centering

If you feel like you're using a lot of trim to get the boat to drive straight, return the steering trim to neutral and mechanically adjust the steering servo linkage.

1. To adjust the linkage, ensure the ESC and servo are powered ON.
2. Loosen the setscrew on the linkage connector with a small, flat-bladed screwdriver.

3. Move the linkage in the connector until the rudder is properly centered
4. Retighten the setscrew.

Boating Tips

Avoid boating near other watercraft, stationary objects, waves, wakes and other rapidly moving water, wildlife, floating debris or overhanging trees. You should also be careful to avoid boating in areas where there are many people, such as swimming areas, park waterways or fishing areas. Consult local laws and ordinances before choosing a location to pilot your boat.

Maximum speeds are only achieved when the water conditions are smooth and there is little wind. A sharp turn, wind or waves can turn over a boat when it is moving quickly. Always pilot your boat for the wind and water conditions so that the boat does not turn over.

When running your boat for the first time, we recommend calm wind and water conditions so that you can learn how the boat responds to your control.

When making turns, decrease the throttle position in order to decrease speed and probability of flipping the boat over.

Operate your boat in water deeper than 5 inches (127mm).

Avoid vegetation in the water so the propeller and rudder are not blocked. However, if these parts are blocked, remove the boat from the water and remove debris.



CAUTION: Never retrieve your boat from the water in extreme temperatures, turbulence or without supervision.

Motor Care

Seat the motor brushes by driving smoothly on calm waters during use of the first battery charge.

- Avoid potential overheating conditions, such as blockage in the cooling tubes, driving against heavy resistance or debris in the drive system.
- Over-temperature protection is installed on the ESC to prevent circuit damage, but cannot protect the motor from turning against heavy resistance.

When You are Finished

1. Power off the ESC.
2. Disconnect the battery.
3. Power off the transmitter.
4. Remove the battery from the boat.

Always store the boat open (without the hatch sealed) or moisture may allow mold and mildew to grow in the boat.

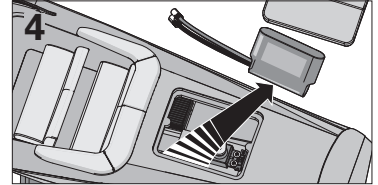
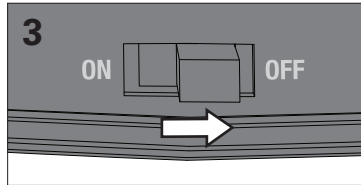
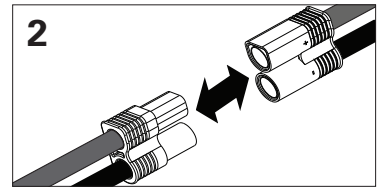
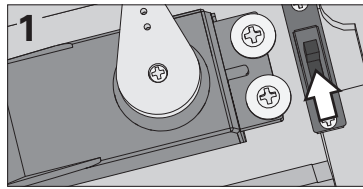

Maintenance and Repair

NOTICE: Some tape and adhesives may damage the finish on your boat. Always test applications on a non-visible part (such as the finish under the seat on the front seat hatch) before applying anything to visible areas of your boat.

If needed, carefully remove dust from your boat with a clean, soft brush or a lint-free, soft cloth.

The scale details on this boat are not intended for manipulation. If needed, apply only small amounts of thin CA (cyanoacrylate adhesive) to repair plastic scale features on your boat. CA may discolor.

When parts are not repairable, see the Replacement Parts List for ordering by item number. For a listing of all replacement and optional parts, refer to the list at the end of this manual.

General Maintenance

Before and at the end of each run, make sure that all screws are tight and that the propeller and rudder turn freely. Lubricate all moving parts with a light household oil after each boating session to prevent binding and corrosion.

CAUTION: Always disconnect the battery from the ESC before performing maintenance on your boat or injury could result.

CAUTION: Always replace the driveshaft when it is damaged or shows visible wear or failure resulting in injury and/or property damage can occur.

Lubrication

Lubricating the driveshaft is vital to the life of the drivetrain. The lubricant also acts as a water seal, keeping water from entering the hull through the stuffing tube.

1. Only magnets hold the seat on the boat. Remove the seat from the cockpit by tipping it rearward and lifting it from the cockpit.
2. Lubricate the stuffing tube through the oil fill port near the motor coupler. Only a few drops of household light machine oil are needed. If desired, put a paper towel under the port to capture stray drops.

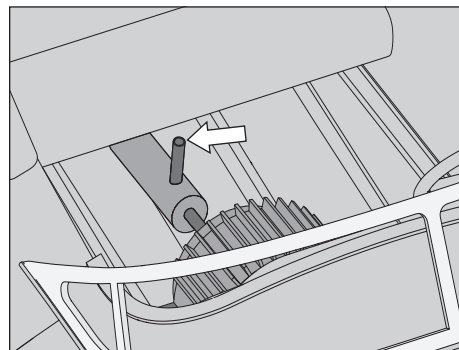

Driveshaft Maintenance

Remove and lubricate the driveshaft after every 2–3 hours of operation with grease. Always replace any parts that show visible wear or damage.

1. If needed, insert a small tool in the hole in the prop nut to turn and remove the nut and propeller from the end of the driveshaft.

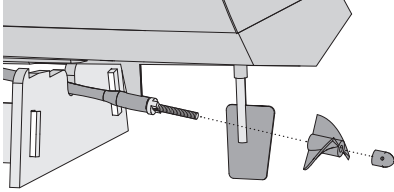

2. Inside the boat, carefully loosen the motor coupler setscrews from the driveshaft using a small flat-bladed screwdriver.

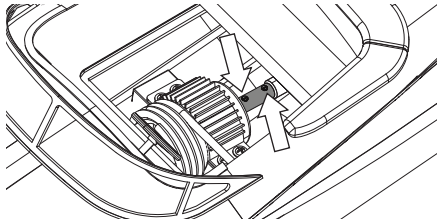

3. Inside the boat, loosen the hex head screw a small amount from the rudder shaft using a 2.5mm ball type hex wrench.

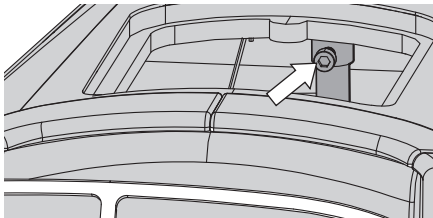

Tip: Use paper or cloth to touch the driveshaft.

4. Remove the rudder from the shaft housing and the driveshaft from the stuffing tube.

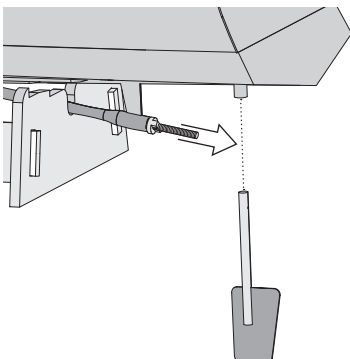

5. Remove lubricant and residue from the driveshaft and rudder shaft using a paper towel and rubbing alcohol or motor spray. If needed, remove residue by careful use of fine sand paper or Emery cloth.
6. Apply a thin coat of marine grease (PRB0101 or PRB0100) to the driveshaft up to the washer by the drive dog and to the rudder shaft.

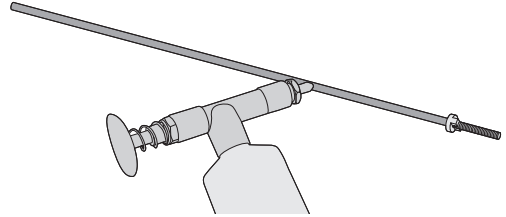

Tip: You do not need to remove the washer and the drive dog from the driveshaft.

7. Carefully reinstall the driveshaft in the stuffing tube and the motor coupler.
8. When tightening the setscrews of the motor coupler on the driveshaft, ensure there is a 1-2mm gap between the washer by the drive dog and the end of the stuffing tube to avoid friction.

IMPORTANT: Apply blue threadlock to the setscrew in the motor coupler. Threadlock will help prevent the driveshaft from loosening during use.

9. With the Volere and radio powered up and the steering in the neutral position, carefully install the rudder in the boat and tighten the hex head screw so the rudder steers the boat straight when the transmitter steering is at neutral.
10. Align the propeller (40 x 32) on the drive dog then tighten the prop nut on the driveshaft using a tool.

NOTICE : Running the boat in saltwater could cause some parts to corrode. If you run the boat in saltwater, rinse it thoroughly in freshwater after each use and lubricate the drive system.

NOTICE: Because of its corrosive effects, running this product in saltwater is at the discretion of the modeler.

Checklists

Before Boating

- Install fully charged batteries in your boat and new AA batteries in your transmitter
- Connect the boat's battery to the ESC
- Make sure the boat is bound to the transmitter (otherwise, bind the boat to the transmitter using the included binding instructions)
- Make sure all linkages move freely on the boat
- Ensure the motor mount is secured to the hull so that the motor does not move
- Perform a Control Direction Test with the transmitter
- Adjust the steering rate on your transmitter as desired
- Find a safe and open area of operation
- Plan a safe route for the water and wind conditions

After Boating

- Always power off the receiver before powering off the transmitter to maintain control of the boat and to retain transmitter binding
- Disconnect the battery from the receiver and remove the batteries from the boat
- Fully dry the inside and outside of the boat, including the water cooling lines and coil around the motor. Remove the hatch before storing your boat.
- Repair any damage or wear to the boat
- Lubricate the driveshaft
- Make note of lessons learned from the trimming of your boat, including water and wind conditions

Tip: The hook and loop strips in the boat retain water. To dry them, press on them with a dry cloth. Use a sponge, paper towel or cloth to remove water from inside the hull.

NOTICE: When you are finished boating, never keep the boat in the sun. Do not store the boat in a hot, enclosed area such as a car. Doing so can damage the boat.

Troubleshooting Guide

Problem	Possible Cause	Solution
Boat will not respond to throttle but responds to other controls	Throttle servo travel is lower than 100%	Make sure throttle servo travel is 100% or greater
	Throttle channel is reversed	Reverse throttle channel on transmitter
Extra noise or extra vibration	Damaged propeller, shaft or motor	Replace damaged parts
	Propeller is out of balance	Balance or replace propeller
Reduced runtime or boat underpowered	Boat battery charge is low	Completely recharge battery
	Boat battery is damaged	Replace boat battery and follow battery instructions
	Blocking or friction on shaft or propeller	Disassemble, lubricate and correctly align parts
	Boat conditions may be too cold	Make sure battery is warm before use
	Battery capacity may be too low for conditions	Replace battery or use a larger capacity battery
	Too little lubrication on driveshaft	Fully lubricate driveshaft
	Vegetation or other obstacles block the rudder or propeller	Remove boat from the water and obstacles

Boat will not Bind (during binding) to transmitter	Transmitter is too near boat during binding process	Move powered transmitter a few feet from boat, disconnect and reconnect battery to boat
	Boat or transmitter is too close to large metal object, wireless source or another transmitter	Move boat and transmitter to another location and attempt binding again
	Boat battery/Transmitter battery charge is too low	Replace/recharge batteries
	Another compatible transmitter is powered on within range of the ESC	Turn off all compatible transmitters except the one you are trying to bind
	ESC switch is off	Power on ESC switch
Boat will not connect (after binding) to transmitter	Transmitter is too near boat during connecting process	Move powered transmitter a few feet from boat, disconnect and reconnect battery to boat
	Boat or transmitter is too close to large metal object, wireless source or another transmitter	Move boat and transmitter to another location and attempt connecting again
	Boat battery/transmitter battery charge is too low	Replace/recharge batteries
	ESC switch is off	Power on ESC switch
Boat tends to dive in the water or takes on water	The boat hull is not completely closed	Dry out the boat and ensure the hatch is fully closed on the hull before returning the boat to the water
	Center of gravity is incorrect	Move the battery in the hull
Boat tends to turn one direction	Rudder or rudder trim is not centered	Repair rudder or adjust rudder and rudder trim for straight running when control is at neutral
Rudder does not move	Rudder, linkage or servo damage	Replace or repair damaged parts and adjust controls
	Wire is damaged or connections are loose	Do a check of wires and connections, connect or replace as needed
	Transmitter is not bound correctly	Re-bind receiver to the transmitter
	BEC (Battery Elimination Circuit) of the ESC is damaged	Replace ESC
	ESC switch is off	Power on ESC switch
Controls reversed	Transmitter settings are reversed	Do the Control Direction Test and adjust controls on transmitter appropriately
Motor overheats	Blocked water cooler tubes	Clean or replace water tubes
Motor power pulses then motor loses power	ESC uses default soft Low Voltage Cut-off (LVC)	Recharge boat battery or replace battery that is no longer performing
	Weather conditions might be too cold	Postpone until weather is warmer
	Battery is old, worn out or damaged	Replace battery
	Battery C rating might be too small	Use recommended battery

Limited Warranty

What this Warranty Covers

Horizon Hobby, Inc., (Horizon) warrants to the original purchaser that the product purchased (the "Product") will be free from defects in materials and workmanship at the date of purchase.

What is Not Covered

This warranty is not transferable and does not cover (i) cosmetic damage, (ii) damage due to acts of God, accident, misuse, abuse, negligence, commercial use, or due to improper use, installation, operation or maintenance, (iii) modification of or to any part of the Product, (iv) attempted service by anyone other than a Horizon Hobby authorized service center, (v) Product not purchased from an authorized Horizon dealer, or (vi) Product not compliant with applicable technical regulations.

OTHER THAN THE EXPRESS WARRANTY ABOVE, HORIZON MAKES NO OTHER WARRANTY OR REPRESENTATION, AND HEREBY DISCLAIMS ANY AND ALL IMPLIED WARRANTIES, INCLUDING, WITHOUT LIMITATION, THE IMPLIED WARRANTIES OF NON-INFRINGEMENT, MERCHANTABILITY AND FITNESS FOR A PARTICULAR PURPOSE. THE PURCHASER ACKNOWLEDGES THAT THEY ALONE HAVE DETERMINED THAT THE PRODUCT WILL SUITABLY MEET THE REQUIREMENTS OF THE PURCHASER'S INTENDED USE.

Purchaser's Remedy

Horizon's sole obligation and purchaser's sole and exclusive remedy shall be that Horizon will, at its option, either (i) service, or (ii) replace, any Product determined by Horizon to be defective. Horizon reserves the right to inspect any and all Product(s) involved in a warranty claim. Service or replacement decisions are at the sole discretion of Horizon. Proof of purchase is required for all warranty claims. SERVICE OR REPLACEMENT AS PROVIDED UNDER THIS WARRANTY IS THE PURCHASER'S SOLE AND EXCLUSIVE REMEDY.

Limitation of Liability

HORIZON SHALL NOT BE LIABLE FOR SPECIAL, INDIRECT, INCIDENTAL OR CONSEQUENTIAL DAMAGES, LOSS OF PROFITS OR PRODUCTION OR COMMERCIAL LOSS IN ANY WAY, REGARDLESS OF WHETHER SUCH CLAIM IS BASED IN CONTRACT, WARRANTY, TORT, NEGLIGENCE, STRICT LIABILITY OR ANY OTHER THEORY OF LIABILITY, EVEN IF HORIZON HAS BEEN ADVISED OF THE POSSIBILITY OF SUCH DAMAGES. Further, in no event shall the liability of Horizon exceed the individual price of the Product on which liability is asserted. As Horizon has no control over use, setup, final assembly, modification or misuse, no liability shall be assumed nor accepted for any resulting damage or injury. By the act of use, setup or assembly, the user accepts all resulting liability. If you as the purchaser or user are not prepared to accept the liability associated with the use of the Product, purchaser is advised to return the Product immediately in new and unused condition to the place of purchase.

Law

These terms are governed by Illinois law (without regard to conflict of law principals). This warranty gives you specific legal rights, and you may also have other rights which vary from state to state. Horizon reserves the right to change or modify this warranty at any time without notice.

WARRANTY SERVICES

Questions, Assistance, and Services

Your local hobby store and/or place of purchase cannot provide warranty support or service. Once assembly, setup or use of the Product has been started, you must contact your local distributor or Horizon directly. This will enable Horizon to better answer your questions and service you in the event that you may need any assistance. For questions or assistance, please visit our website at www.horizonhobby.com, submit a Product Support Inquiry, or call the toll free telephone number referenced in the Warranty and Service Contact Information section to speak with a Product Support representative.

Inspection or Services

If this Product needs to be inspected or serviced and is compliant in the country you live and use the Product in, please use the Horizon Online Service Request submission process found on our website or call Horizon to obtain a Return Merchandise Authorization (RMA) number. Pack the Product securely using a shipping carton. Please note that original boxes may be included, but are not designed to withstand the rigors of shipping without additional protection. Ship via a carrier that provides tracking and insurance for lost or damaged parcels, as Horizon is not responsible for merchandise until it arrives and is accepted at our facility. An Online Service Request is available at http://www.horizonhobby.com/content/_service-center_render-service-center. If you do not have internet access, please contact Horizon Product Support to obtain a RMA number along with instructions for submitting your product for service. When calling Horizon, you will be asked to provide your complete name, street address, email address and phone number where you can be reached during business hours. When sending product into Horizon, please include your RMA number, a list of the included items, and a brief summary of the problem. A copy of your original sales receipt must be included for warranty consideration. Be sure your name, address, and RMA number are clearly written on the outside of the shipping carton.

NOTICE: Do not ship LiPo batteries to Horizon. If you have any issue with a LiPo battery, please contact the appropriate Horizon Product Support office.

Warranty Requirements

For Warranty consideration, you must include your original sales receipt verifying the proof-of-purchase date. Provided warranty conditions have been met, your Product will be serviced or replaced free of charge. Service or replacement decisions are at the sole discretion of Horizon.

Non-Warranty Service

Should your service not be covered by warranty, service will be completed and payment will be required without notification or estimate of the expense unless the expense exceeds 50% of the retail purchase cost. By submitting the item for service you are agreeing to payment of the service without notification. Service estimates are available upon request. You must include this request with your item submitted for service. Non-warranty service estimates will be billed a minimum of ½ hour of labor. In addition you will be billed for return freight. Horizon accepts money orders and cashier's checks, as well as Visa, MasterCard, American Express, and Discover cards. By submitting any item to Horizon for service, you are agreeing to Horizon's Terms and Conditions found on our website http://www.horizonhobby.com/content/_service-center_render-service-center.

ATTENTION: Horizon service is limited to Product compliant in the country of use and ownership. If received, a non-compliant Product will not be serviced. Further, the sender will be responsible for arranging return shipment of the un-serviced Product, through a carrier of the sender's choice and at the sender's expense. Horizon will hold non-compliant Product for a period of 60 days from notification, after which it will be discarded.

Warranty and Service Contact Information

Country of Purchase	Horizon Hobby	Contact Information	Address
United States of America	Horizon Service Center (Repairs and Repair Requests)	servicecenter.horizonhobby.com/RequestForm/	4105 Fieldstone Rd Champaign, Illinois, 61822 USA
	Horizon Product Support (Product Technical Assistance)	www.quickbase.com/db/bghj7ey8c?a=GenNewRecord	
		888-959-2306	
	Sales	sales@horizonhobby.com 888-959-2306	
United Kingdom	Service/Parts/Sales: Horizon Hobby Limited	sales@horizonhobby.co.uk +44 (0) 1279 641 097	Units 1-4 , Ployters Rd, Staple Tye Harlow, Essex, CM18 7NS, United Kingdom
Germany	Horizon Technischer Service	service@horizonhobby.de	Christian-Junge-Straße 1 25337 Elmshorn, Germany
	Sales: Horizon Hobby GmbH	+49 (0) 4121 2655 100	
France	Service/Parts/Sales: Horizon Hobby SAS	infofrance@horizonhobby.com +33 (0) 1 60 18 34 90	11 Rue Georges Charpak 77127 Lieusaint, France
China	Service/Parts/Sales: Horizon Hobby – China	info@horizonhobby.com.cn +86 (021) 5180 9868	Room 506, No. 97 Changshou Rd. Shanghai, China 200060

FCC Information

This device complies with part 15 of the FCC rules. Operation is subject to the following two conditions:

- (1) This device may not cause harmful interference, and
- (2) This device must accept any interference received, including interference that may cause undesired operation.



CAUTION: Changes or modifications not expressly approved by the party responsible for compliance could void the user's authority to operate the equipment.

This product contains a radio transmitter with wireless technology which has been tested and found to be compliant with the applicable regulations governing a radio transmitter in the 2.400GHz to 2.4835GHz frequency range.

IC Information

This device complies with Industry Canada licence-exempt RSS standard(s). Operation is subject to the following two conditions: (1) this device may not cause interference, and (2) this device must accept any interference, including interference that may cause undesired operation of the device.

Compliance Information for the European Union

Declaration of Conformity

(in accordance with ISO/IEC 17050-1)

No. HH2012121501

Product(s): PRB Volere 22 EP 2.4GHz RTR

Item Number(s): PRB3050BI

Equipment class: 1

The object of declaration described above is in conformity with the requirements of the specifications listed below, following the provisions of the European R&TTE directive 1999/5/EC, EMC Directive 2004/108/EC and LVD Directive 2006/95/EC:

EN 300-328 V1.7.1: 2006

EN 301 489-1 V1.7.1: 2006

EN 301 489-17 V1.3.2: 2008

EN60950-1:2006+A11:2009+A1:2010+A12: 2011

EN55022:2010 + AC:2011

EN55024:2010

EN61000-3-2:2006+A1:2009+A2:2009

EN61000-3-3:2008



Signed for and on behalf of:
Horizon Hobby, Inc.
Champaign, IL USA
Dec 15, 2012

Steven A. Hall
Executive Vice President and Chief Operating Officer
International Operations and Risk Management
Horizon Hobby, Inc.



Instructions for Disposal of WEEE by Users in the European Union

This product must not be disposed of with other waste. Instead, it is the user's responsibility to dispose of their waste equipment by handing it over to a designated collection point for the recycling of waste electrical and electronic equipment. The separate collection and recycling of your waste equipment at the time of disposal will help to conserve natural resources and ensure that it is recycled in a manner that protects human health and the environment. For more information about where you can drop off your waste equipment for recycling, please contact your local city office, your household waste disposal service or where you purchased the product.

Identification of Components / Identifizierung der Komponenten
Identification des composants / Identificazione dei componenti

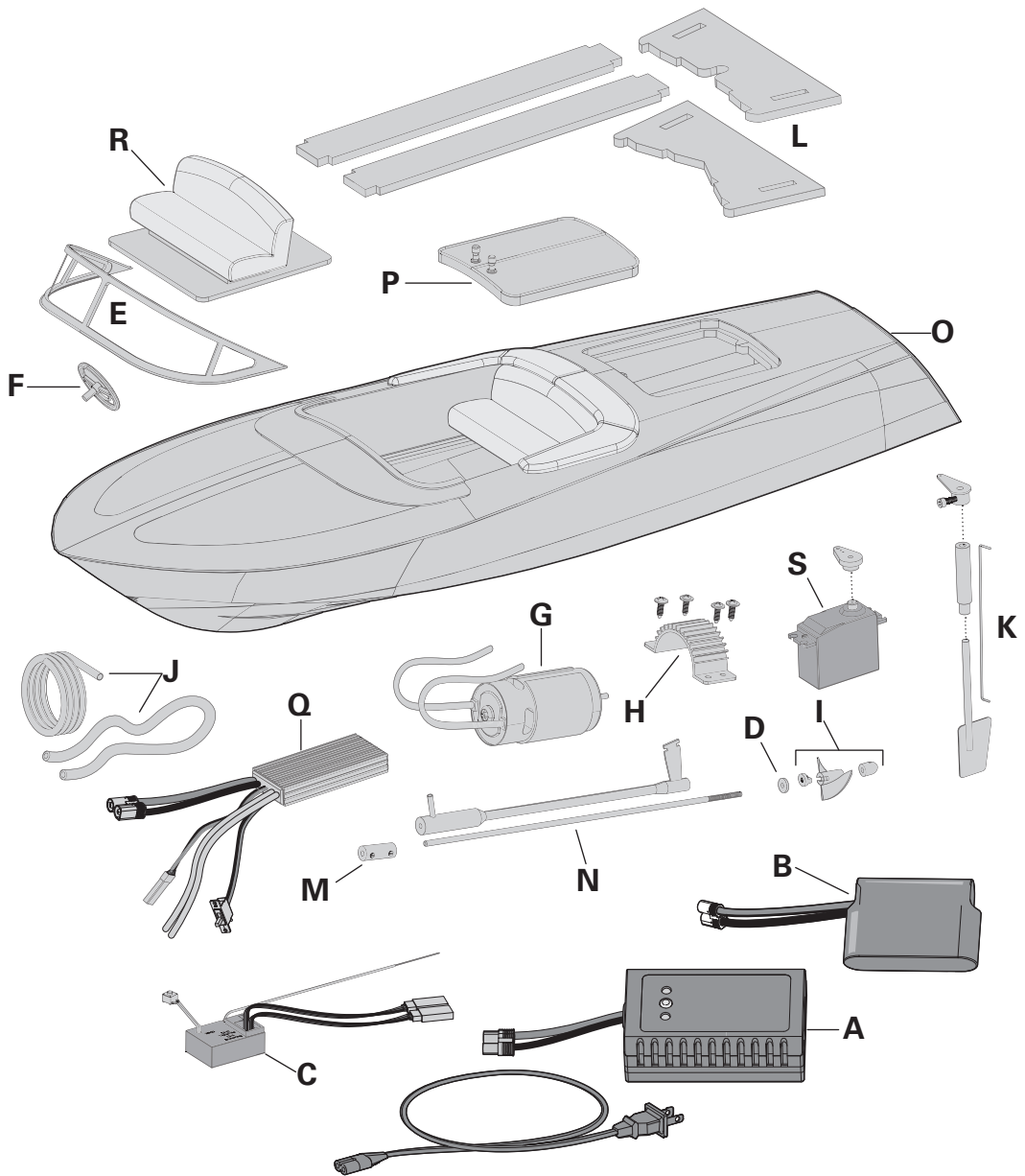

Replacement Parts / Ersatzteile / Pièces de rechange / Pezzi di ricambio

Part # Nummer Numéro Codice	Description	Beschreibung	Description	Descrizione
A DYN4113	2A Peak Charger	2A Peak Ni-MH Ladegerät	2A Chargeur à détection de pics	2A Caricabatterie a rilevamento di picchi
B DYN1472	7.2V 1200mAh Ni-MH battery w/EC3	Dynamite 7.2V 1200mAh Ni-MH Akku m /EC3 Stecker	Batterie Ni-MH 7.2V 1200mA	Batteria 7.2V 1200mAh Ni-MH c/ EC3
ECX9010	2.4GHz 2-Channel Pro Boat Radio	ECX Coltsender 2 Kanal 2.4Ghz	Emetteur ProBoat 2.4GHz	Radio ProBoat 2.4GHz 2-canali
C ECX9011	ECX 2.4GHz Receiver, Water Proof	ECX Empfänger wasserfest 2.4Ghz	Récepteur ECX 2.4GHz étanche	Ricevitore impermeabile ECX 2.4GHz
D PRB2219	Nylon Propeller Washer, 8x3x1.5 mm	Proboat Volere: Windschutzscheibe	Rondelle nylon d'hélice, 8x3x1.5 mm	Rondella elica in nylon, 8x3x1.5 mm
E PRB3053	Windshield: Volere	Proboat Volere: Windschutzscheibe	Pare brise	Parabrezza: Volere
F PRB3054	Steering Wheel: Volere	Proboat Volere: Windschutzscheibe	Volant	Ruota timone: Volere
G PRB3056	550 Motor: Volere	550er Motor	Moteur 550	Motore 550
H PRB3057	Motor Mount: Volere	Motorhalterung	Support moteur	Montante motore
I PRB3058	Propeller with Drive Dog: Volere	Proboat Volere: Propeller mit Drive Dog	Hélice avec entraîneur	Elica con trascinato: Volere
J PRB3059	Cooling System: Volere	Kühlsystem: Volere	Système de refroidissement: Volere	Sistema di raffreddamento: Volere
K PRB3061	Rudder with Linkage: Volere	Proboat Volere: Ruder mit Anlenkung	Gouvernail avec tringlerie	Timone con comando: Volere
L PRB3063	Boat Stand: Volere	Bootständer	Support de bateau	Supporto imbarcazione
PRB3064	Decal Sheet: Volere	Proboat Dekorbogen: Dekorbogen	Planche de décoration	Foglio adesivi: Volere
M PRB3065	Motor Coupler: Volere	Motorkupplung: Volere	Coupleur de moteur: Volere	Giunto motore: Volere
N PRB3066	Driveshaft with Stuffing Tube: Volere	Proboat Volere: Welle kpl.	Arbre de transmission avec son tube	Trasmissione completa: Volere
PRB3067	Hull Accessories: Volere	Proboat Volere: Rumpfacessories	Accessoires de coque	Accessori scafo: Volere
O PRB3068	Hull w/Mtr and Rudder Inst: Volere V2	Proboat Volere 22 EP: Rumpf	Coque avec gouvernail	Scafo c/mot. e timone inst.: Volere V2
P PRB3069	Rear Hatch Cover: Volere	Proboat Volere 22 EP: Abdeckung Heck	Trappe arrière	Portello posteriore: Volere
Q PRB3070	30 amp ESC w/ Reverse: Volere	Proboat Volere 22 EP: 30A ESC V/R Regler	Variateur électronique 30A avec marche arrière	ESC 30A c/ retromarcia: Volere
R PRB3071	Front Seat: Volere	Proboat Volere 22 EP: Frontsitz	Sièges avant	Sedile anteriore: Volere
PRB4012	Antenna Tube	Antennenröhrchen	Tube d'antenne	Tubetto antenna
S ECX13000	3KG Waterproof Steering Servo	325WP 3kg Kunststoff Servo Spritzwasserdicht	Servo de direction étanche 3kg	Servo timone impermeabile 3kg

Optional Parts / Diverse Teile / Pièces optionnelles / Componenti opzionali

PRB0100	Marine grease	Marinefett	Graisse marine	Grasso marino
PRB0102	Waterproof tape	Clearflex Klebeband	Ruban adhésif imperméable	Nastro impermeabile
(DYN5500)	Magnum Force 2 Motor Spray, 13 oz	Magnum Force Motorreinigungsspray. 390ml	Bombe de nettoyant moteur Magnum Force, 380mL	Spray motore Magnum Force 2, 13 oz (370g)

